



HY-40R201W/WC 硬件规格书

文档版本：V2.3

2019 年 08 月 26 日

深圳市昇润科技有限公司版权所有

昇润科技对本手册中可能出现的错误不承担责任。此外，昇润科技保留随时更改硬件，软件和/或规格书的权利，恕不另行通知，并不承诺更新此处所包含的信息。昇润的产品不被授权使用作生命支持设备或系统中的关键组件。以及不承担各种专利或知识产权的授权使用；蓝牙商标是由美国蓝牙 SIG 公司所有。

版本	修订日期	修订人	审稿人	修订内容
V1.0	2017/08/07	GKL	LYC	初版
V2.0	2017/10/17	WF/ZLL	LYC	1. 增加陶瓷天线机种及修改型号 2. 增加应用说明注记 3. 增加 FCC IC 号 4. 变更文件格式
V2.1	2017/10/25	WF	LYC	1. 增加 RF 安规已认证说明及 IC ID 号码
V2.2	2019/06/12	FJ	LYC	1.增加天线馈入点 RF 特性及静电防护说明.
V2.3	2020/8/26	JOE	GWB	更改商业地址

表 1 版本历史

目录

1. 简述	1
1-1 应用	1
1-2 主要特征	1
2. 产品型号	2
2-1. 带屏蔽罩或不带屏蔽罩可选	2
3. 模块尺寸与图片	2
3.1 HY-40R201W / MD40R201SR6W0 金属线天线 (1/4 波长单极子天线)	2
4. 应用注意事项	2
5. 引脚分配和端口功能说明	4
6. 电气特性	5
6-1. 射频特性 及 电流功耗	5
6-2. 绝对最大额定值	6
6-3. ESD 额定值	6
6-4. 建议工作条件	6
6-5. GPIO DC 特性	7
6-6. 时序要求	7
6-7. 动作状态切换时序特性	7
7. 模块方块图	8
8. IC 功能方块图	8
9. 工作模式架构图	9
10. 回流焊曲线建议	9
11. HY-40R201PC / WMD40R201SR6PC 模块 FCC 及 IC 声明	10
12. 联系我们	13

1. 简述

HY-40R201W/WC 蓝牙低功耗单模模块是针对低功率传感器和附近的单模设备。HY-40R201W/WC 提供蓝牙低功耗特性：无线电，蓝牙协议栈，配置文件和客户应用程序的所需空间。该模块还提供灵活的硬件接口，用于连接传感器。

HY-40R201W/WC 可以使用标准 3V 纽扣电池或一对 AAA 电池直接供电，最低功耗关断模式下，它仅消耗 0.15uA，并在几微秒内唤醒。

蓝牙 IC: TTC2640R2 6*6*0.9mm 48pin IC, 使用 TI CC2640R2 芯片

1-1 应用

- 健身类：运动手环，计步器，运动计量（跑步，自行车，高尔夫）。
- 智能家居类：插座改造，遥控开关，调光调色照明，门锁，窗帘，温湿度计，智能秤，环境烟雾测探测器，宠物监管。
- 健康医疗类：医疗检测/追踪（心率，血压，血氧，脉搏，体温）。
- 婴幼儿护理：实时体温检测，智能婴儿床，防丢失。
- 玩具类：互动遥控玩具，机器人，飞行器，玩具车，防丢器。
- 汽车电子：胎压检测，汽车自动锁，车位记录，电动车防盗器，数据采集监控。
- 人机界面：HID 键盘、鼠标、遥控器、手柄。

1-2 主要特征

- 蓝牙 BLE 5.0，单模兼容
- 支持主机模式，从机模式，主从模式
- 集成蓝牙低功耗堆叠
- GAP, GATT, L2CAP, SMP 蓝牙低功耗配置文件
- 已先经过 BQB BLE5.0, CE, FCC, Canada IC. 射频安规认证, (FCC 及 IC 认证仅为 HY-40R201PC PCB 天线有屏蔽罩机种); 另外可满足其他各国射频安规特性。
- 超低电流功耗
 - 1) 待机状态：3uA (RTC 运行和 RAM / CPU 保持)
 - 2) 关机状态：150nA (无时钟运行，无存储)
- 可编程 ARM Cortex-M3 处理器，用于嵌入完整的应用程序

2. 产品型号

2-1. 带屏蔽罩或不带屏蔽罩可选

料号	硬件型号	说明
WMD40R201SR6W0	HY-40R201W	金属线天线, 不带屏蔽罩
WMD40R201SR6WC	HY-40R201WC	金属线天线, 带屏蔽罩

3. 模块尺寸与图片

3.1 HY-40R201W / MD40R201SR6W0 金属线天线 (1/4 波长单极子天线)

及 HY-40R201WC/WMD40R201SR6WC 金属线天线带屏蔽罩机种.

尺寸: (23.2*15.22*2.0/2.6mm)

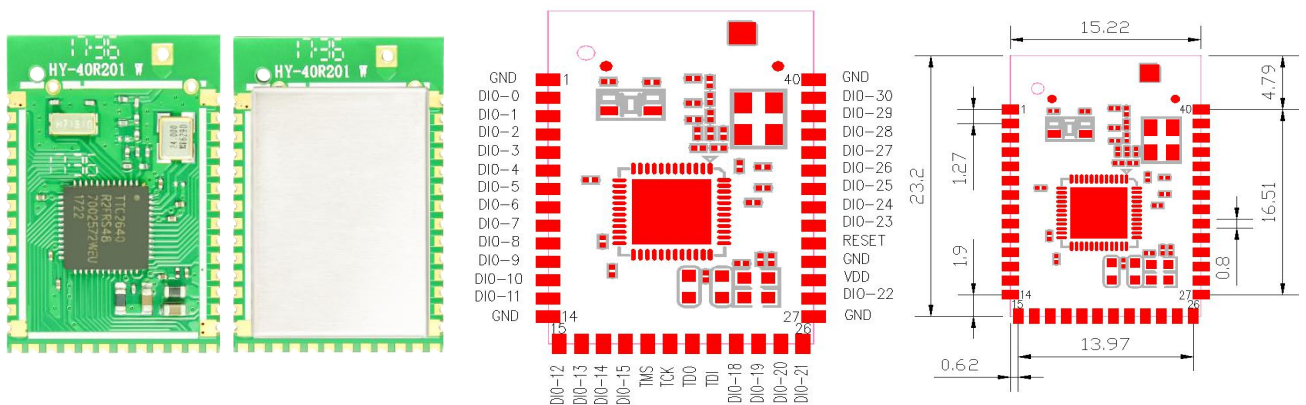

4. 应用注意事项

4-1. 注意静电防护, 作业过程中, 确保仪器, 设备接地完全及防静电保护, 防止烙铁及各设备接地不良及工作台, 工作环境, 包材及人体触摸等产生静电, 破坏 IC 及程序被打飞; 手工焊接模块时需注意烙铁温度, 避免 PCB 铜皮剥离脱落; 烙铁严格要求完全接地, 避免烙铁电源破坏模块; 作业员确实配戴防静电环与落实静电防护检验, 防止人体触摸破坏 IC 及程序

4-1a: 烙铁焊头对地阻抗在 $10\ \Omega$ 以内, 漏电压 $< 0.1V$, 确认烙铁头与烙铁头套之间须接触良好, 避免氧化接触不良; 环境及人员静电电压在 $0 \pm 100V$ 以内. 作业区域做好防静电标示.

4-2. 注意避免整体主板之电源回路不良焊接短路相连或开路时, 造成蓝牙芯片电压异常, 致使程序被打飞及 IC 被破坏之问题

4-3. 当模块闪存刻录程序固件时, VDD5 直流电源电压需在 $2.4 \sim 3.3V$ 之间, 避免刻录时有不完全之异常状况发生.

4-4. 使用模块在生产及运送过程, 敬请善尽模块零件保护措施, 防止模块上的精密

零件碰坏(回焊炉出口及装配,测试,运送过程,建议用防碰撞材料缓冲,不可相互碰撞)

4-5.本模块为湿度敏感元器件,若使用在贴片回流焊作业时,敬请严格遵从 IPC/ JEDECJ-STD-020 规定,先做好干燥除湿作业,又因本模块已为 2 次加工作业后放置在功能测试环境中,芯片内的湿度无法保证在一定的比值,敬请贵客了解;

(上述注意事项如下各示意图:)



4-6.模块应用原理图上的外接滤波零件,在主板需要时请接上,数值可依整板特性实际需要变更;

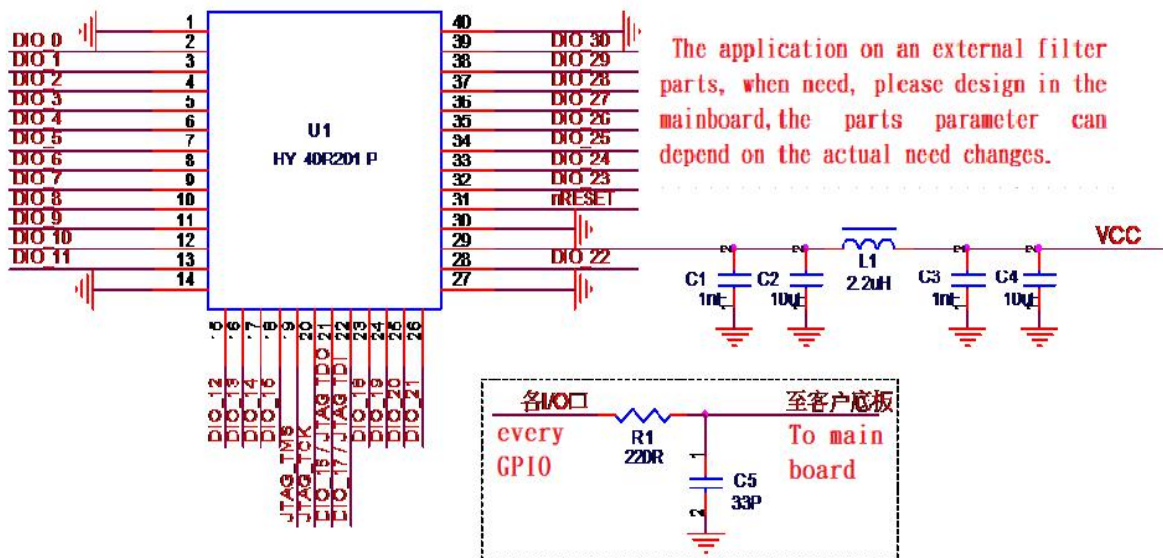

模块焊装在主板上时须注意:天线周围及各层铜箔须净空,模块天线需放在主板的边缘.且不能有金属或妨碍电磁辐射的材质包裹在四周。

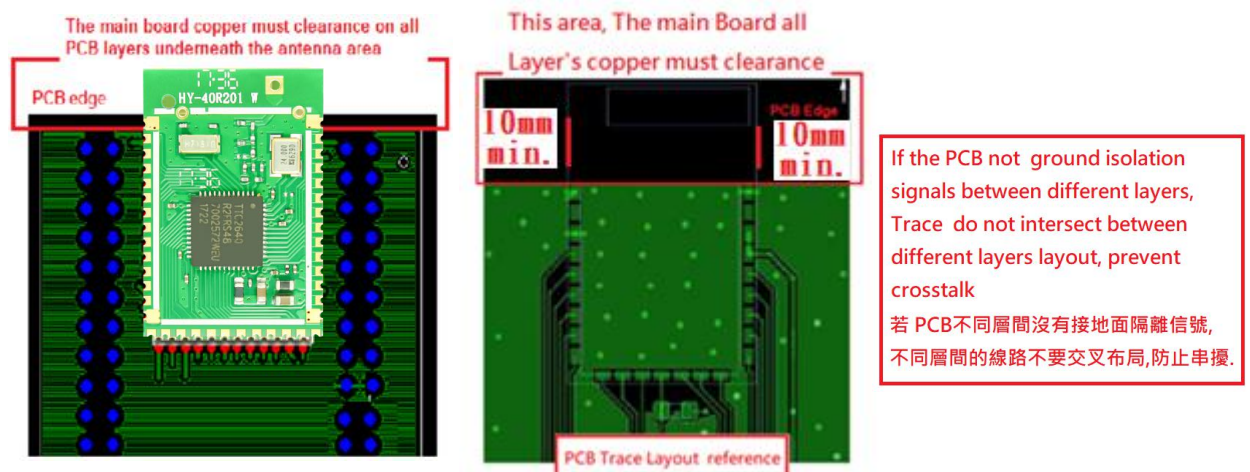

5. 引脚分配和端口功能说明

脚位	名称	类型	功能描述
1	GND	Power GND	Ground
2	DIO_0	Digital I/O	GPIO, Sensor Controller (I:4mA max)
3	DIO_1	Digital I/O	GPIO, Sensor Controller (I:4mA max)
4	DIO_2	Digital I/O	UART RX; GPIO, Sensor Controller (I:4mA max),
5	DIO_3	Digital I/O	UART TX; GPIO, Sensor Controller (I:4mA max)
6	DIO_4	Digital I/O	WAKE UP; Don't floating GPIO, Sensor Controller (I:4mA max)
7	DIO_5	Digital I/O	GPIO, Sensor Controller, high-drive capability (8mA max).
8	DIO_6	Digital I/O	GPIO, Sensor Controller, high-drive capability (8mA max).
9	DIO_7	Digital I/O	GPIO, Sensor Controller, high-drive capability (8mA max).
10	DIO_8	Digital I/O	GPIO (I: 4mA max)
11	DIO_9	Digital I/O	GPIO (I: 4mA max)
12	DIO_10	Digital I/O	GPIO (I: 4mA max)
13	DIO_11	Digital I/O	GPIO (I: 4mA max)
14	GND	Power GND	Ground
15	DIO_12	Digital I/O	GPIO (I: 4mA max)
16	DIO_13	Digital I/O	GPIO (I: 4mA max)
17	DIO_14	Digital I/O	GPIO (I: 4mA max)
18	DIO_15	Digital I/O	GPIO (I: 4mA max)
19	JTAG TMSC	Digital I/O	JTAG TMSC; high-drive capability
20	JTAG TCKC	Digital I/O	JTAG TCKC
21	DIO_16 TDO	Digital I/O	GPIO, JTAG_TDO, high-drive capability(8mA max).
22	DIO_17 TDI	Digital I/O	GPIO, JTAG_TDI. high-drive capability(8mA max).
23	DIO_18	Digital I/O	GPIO (I: 4mA max)
24	DIO_19	Digital I/O	GPIO (I: 4mA max)
25	DIO_20	Digital I/O	GPIO (I: 4mA max)

26	DIO_21	Digital I/O	GPIO (I: 4mA max)
27	GND	Power GND	Ground
28	DIO_22	Digital I/O	GPIO (I: 4mA max)
29	VDD	Power supply	+1.8V to +3.8V (Recommended 2.7~3.3V)
30	GND	Power GND	Ground
31	RESET_N	Digital input	Reset, active-low. Module have pull up.
32	DIO_23	Digital I/O	GPIO, Sensor Controller, Analog(I: 4mA max)
33	DIO_24	Digital I/O	GPIO, Sensor Controller, Analog(I: 4mA max)
34	DIO_25	Digital I/O	GPIO, Sensor Controller, Analog(I: 4mA max)
35	DIO_26	Digital I/O	GPIO, Sensor Controller, Analog(I: 4mA max)
36	DIO_27	Digital I/O	GPIO, Sensor Controller, Analog(I: 4mA max)
37	DIO_28	Digital I/O	GPIO, Sensor Controller, Analog(I: 4mA max)
38	DIO_29	Digital I/O	GPIO, Sensor Controller, Analog(I: 4mA max)
39	DIO_30	Digital I/O	GPIO, Sensor Controller, Analog(I: 4mA max)
40	GND	Power GND	Ground

6. 电气特性

(测试条件: $T_a = 25\text{ }^{\circ}\text{C}$, $V_{DD} = 3.0\text{V}$ 带内部 DC-DC 稳压器,测试标准:1Mbps GFSK 调制 ,FRF = 2440MHz 蓝牙低功耗模式.)

6-1. 射频特性 及 电流功耗

- 调制方式: GFSK
- 频率范围: 2402~2480MHz (2.4G ISM 频带)
- IC 发射功率范围: -21~+5dBm typical (由软件编程控制)
- 天线馈入端 RF 发射功率 : +3 dBm typical. (RF TX 设置在+5dBm 最大值特性)
- 天线馈入端 RF 接收灵敏度: -93dBm typical (在 PER <30.8%特性)
- 频率偏移值 :RF $\pm 60\text{ppm}$,MCU clock 32.768KHz $\pm 350\text{ppm}$ (使用晶振模式)
- 已先经过 BQB BLE5.0, CE, FCC, Canada IC.射频安规认证,(FCC 及 IC 认证仅为 HY-40R201PC PCB 天线有屏蔽罩机种); 另外可满足其他各国射频安规特性.
 - 超低电流功耗
 - 1.RF TX 电流: 6.1mA (0dBm)
 - 2.RF TX 电流: 9.1mA (5dBm)
 - 3.RF RX 电流: 5.9mA

- 4.空闲状态：550 μ A（支持系统和 RAM 供电）
- 5.待机状态：3 μ A（RTC 运行和 RAM / CPU 保持）
- 6.关机状态：150nA（无时钟运行，无存储）

6-2. 绝对最大额定值

注意：这些是绝对最大额定值，超过该额定值，模块可能永久损坏，这些不是最大工作条件，最大推荐工作条件见 6-4。

额定值	最小	最大	单位
VDD	-0.3	3.8	V
其他端子电压	VSS-0.3	VDD+0.3	V
储存温度	-40	+125	° C

6-3. ESD 额定值

		数值	单位
V _{ESD} 静电 放电	人体模式(HBM), 依据 ANSI / ESDA / JEDEC/JS001	所有引脚	±2500
	充电设备模式, 依据 JESD22-C101	RF 引脚	±750
		非 RF 引脚	±750
			V

6-4. 建议工作条件

电源电压噪声应小于 10mV_{pp}，过大的电源噪声，会降低射频性能。

额定值	最小	最大	单位
VDD(蓝牙动作时)	1.8	3.6	V
VDD(闪存刻录程序固件时)	2.4	3.3	V
工作温度	-40	+85	° C

备注:(1).VDD 直流电源供应推荐电压: 2.7~3.3V DC.

(2).当模块闪存刻录程序固件时,VDD+0.3 直流电源电压需在 2.4~3.3V 之间,避免刻录时有不完全,或异常状况发生.

(3).对于纽扣电池,在最坏情况下,电池等效源电阻会造成电源压降,这时 VDD+0.3 必须

使用一个 22 μ F 的输入电容,加强电源能力,以确保符合该转换速率(6-6 时序要求)。

6-5.GPIO DC 特性

参数	测试条件	典型值	单位
8-mA 负载 GPIO 高电平输出	IOCURR = 2, 限高驱动的 GPIOs	2.68	V
8-mA 负载 GPIO 低电平输出	IOCURR = 2, 限高驱动的 GPIOs	0.33	V
4-mA 负载 GPIO 高电平输出	IOCURR = 1	2.72	V
4-mA 负载 GPIO 低电平输出	IOCURR = 1	0.28	V

6-6. 时序要求

说明		最小	标准	最大	单位
上升电源电压转换速率		0		100	mV/ μs
下降电源电压转换速率		0		20	mV/ μs
下降电源电压转换速率——低功率闪存环境 ⁽¹⁾				3	mV/ μs
待机正温度梯度 ⁽²⁾	负温度梯度或外部待机模式没有限制			5	° C/s
输入控制的交流特性					
复位 RESET_N 保持低的持续时间		1			μs

(1) 对于纽扣电池, 在最坏情况下, 电池等效源电阻会造成电源压降, 这时 V_{DDS} 必须使用一个 22μF 的输入电容, 加强电源能力, 以确保符合该转换速率。

(2) 使用 RCOSC_LF 作为睡眠定时器的应用, 必须考虑温度变化引起的频率漂移。

6-7. 动作状态切换时序特性

测量条件 T_c = 25° C, V_{DDS} = 3.0 V, 除非另有说明

参数	测试条件	最小	典型	最大	单位
唤醒和时序					
Idle → Active			14		μs
Standby → Active			151		μs
Shutdown → Active			1015		μs

7. 模块方块图

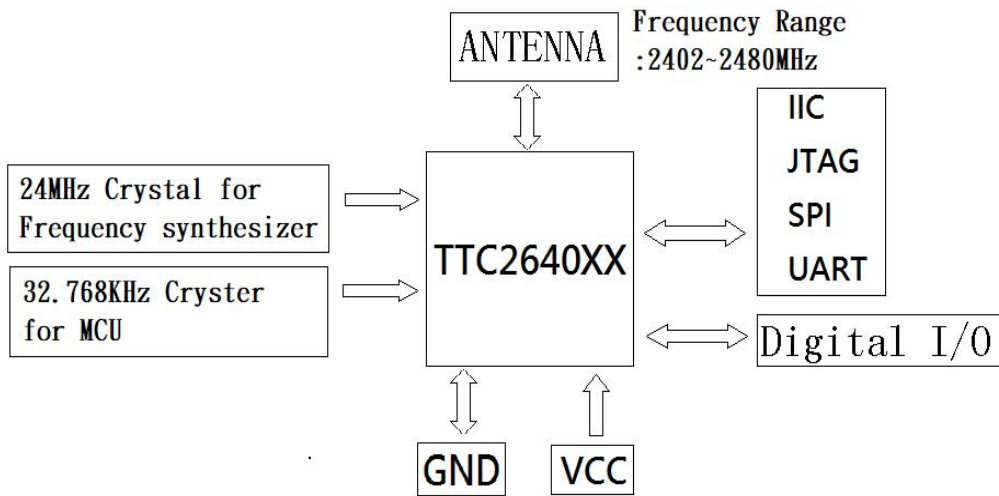

8.IC 功能方块图

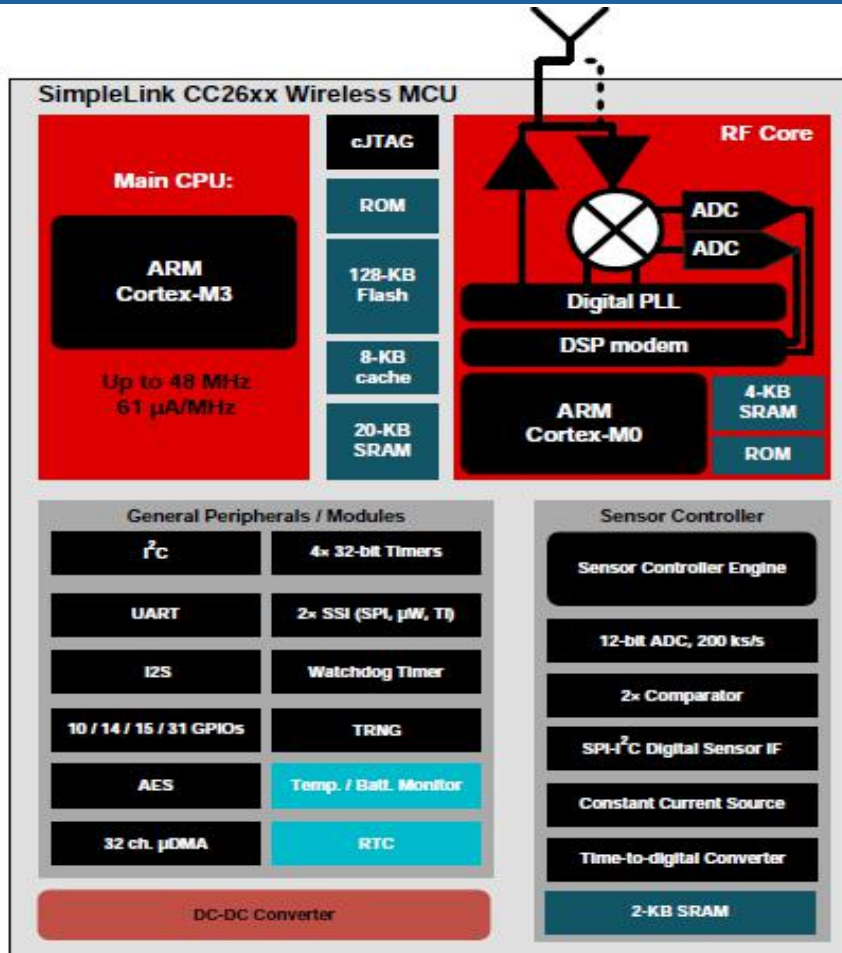

9. 工作模式架构图

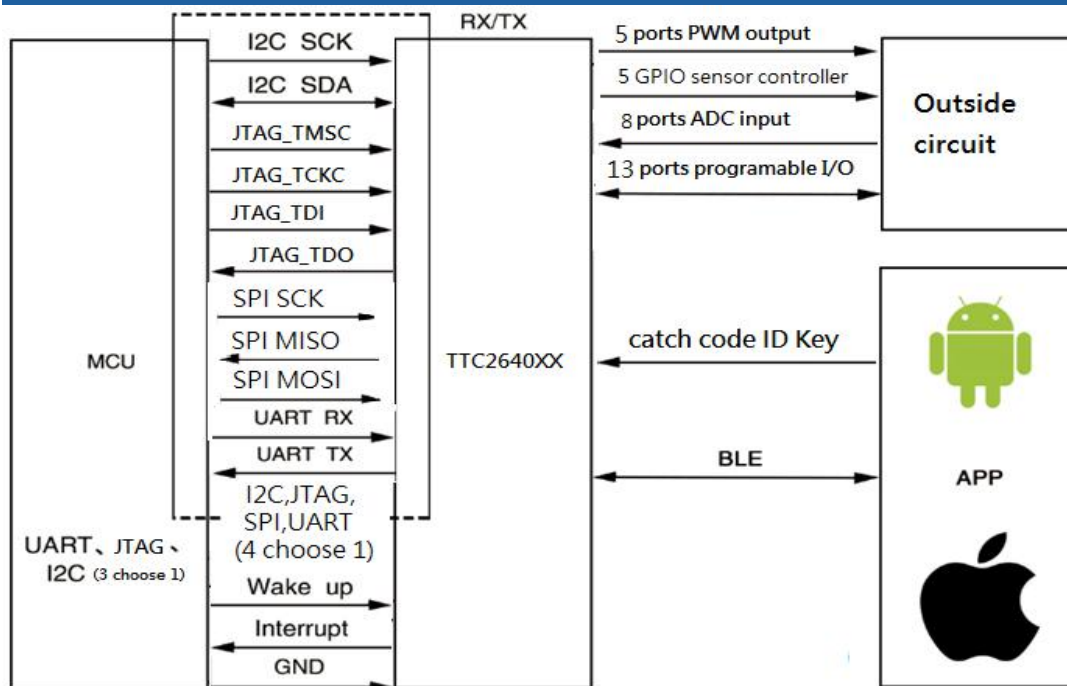

10. 回流焊曲线建议

(无铅锡膏: Sn 96.5%, Ag 3%, Cu 0.5%)

Profile Feature	Pb-Free Assembly	
	Large Body	Small Body
Average ramp-up rate(T_L to T_P)	3° C/second max	
Preheat	-Temperature Min ($T_{s_{min}}$) 150° C -Temperature Max ($T_{s_{max}}$) 200° C -Time (min to max)(ts) 60-180 seconds	
$T_{s_{max}}$ to $T_{L_{min}}$ -Ramp-up Rate	3° C/second max	
Time maintained above -Temperature (T_L) -Time (t_L)	217° C 60-150 seconds	
Peak Temperature (T_P)	245 +0/-5° C	250 +0/-5° C
Time within 5° C of actualPeakTemperature (t_p)	10-30 seconds	20-40 seconds
Ramp-down Rate	6° C/second max	
Time 25° C to PeakTemperature	8 minutes max	

回流曲线分类

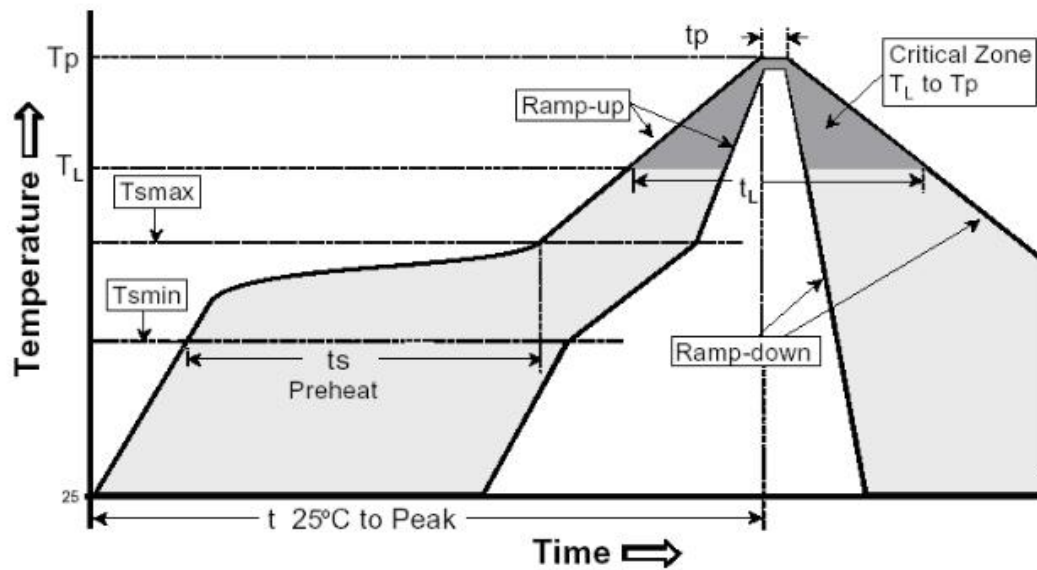

11. HY-40R201PC / WMD40R201SR6PC 模块 FCC 及 IC 声明

FCC /加拿大工业部声明 (被放置在最终产品) 联邦通信委员会 (FCC) 声明
 HY-40R201PC/WMD40R201SR6PC Module FCC/Industry Canada Statement (to
 be placed on End Products)Federal Communications Commission (FCC) Statement
 FCC Statements

(OEM) Integrator has to assure compliance of the entire end-product incl. the
 integrated RF Module. For 15 B (§ 15.107 and if applicable § 15.109) compliance,
 the host manufacturer is required to show compliance with 15 while the module is
 installed and operating.

Furthermore the module should be transmitting and the evaluation should confirm
 that the module's intentional emissions (15C) are compliant (fundamental /
 out-of-band). Finally the integrator has to apply the appropriate equipment
 authorization (e.g. Verification) for the new host device per definition in § 15.101.

Integrator is reminded to assure that these installation instructions will not be made
 available to the end-user of the final host device.

The final host device, into which this RF Module is integrated" has to be labeled with
 an auxiliary label stating the FCC ID of the RF Module, such as "Contains FCC ID:
 2ADXE-HY-40R201PC

"This device complies with part 15 of the FCC rules. Operation is subject to the

following two conditions:

- (1) this device may not cause harmful interference, and
- (2) this device must accept any interference received, including interference that may cause undesired operation."

"Changes or modifications to this unit not expressly approved by the party responsible for compliance could void the user's authority to operate the equipment."

the Integrator will be responsible to satisfy SAR/ RF Exposure requirements, when the module integrated into the host device.

Module statement

The single-modular transmitter is a self-contained, physically delineated, component for which compliance can be demonstrated independent of the host operating conditions, and which complies with all eight requirements of § 15.212(a)(1) as summarized below.

- 1) The radio elements have the radio frequency circuitry shielded.
- 2) The module has buffered modulation/data inputs to ensure that the device will comply with Part 15 requirements with any type of input signal.
- 3) The module contains power supply regulation on the module.
- 4) The module contains a permanently attached antenna.
- 5) The module demonstrates compliance in a stand-alone configuration.
- 6) The module is labeled with its permanently affixed FCC ID label.
- 7) The module complies with all specific rules applicable to the transmitter, including all the conditions provided in the integration instructions by the grantee.
- 8) The module complies with RF exposure requirements.

NOTE: This equipment has been tested and found to comply with the limits for a Class B digital device, pursuant to part 15 of the FCC Rules. These limits are designed to provide reasonable protection against harmful interference in a residential installation. This equipment generates uses and can radiate radio frequency energy and, if not installed and used in accordance with the instructions, may cause harmful interference to radio communications. However, there is no guarantee that interference will not occur in a particular installation. If this equipment does cause harmful interference to radio or television reception, which can be determined by turning the equipment off and on, the user is encouraged to try to correct the interference by one or more of the following measures:

- Reorient or relocate the receiving antenna.
- Increase the separation between the equipment and receiver.
- Connect the equipment into an outlet on a circuit different from that to which the receiver is connected.

-Consult the dealer or an experienced radio/TV technician for help
Industry Canada (IC) Statement

This device complies with Industry Canada licence - exempt RSS standard(s).

Operation is subject to the following two conditions:

- (1) This device may not cause interference, and
- (2) This device must accept any interference, including interference that may cause undesired operation of the device.

Canada, avis d' Industrie Canada (IC)

Le présent appareil est conforme aux CNR d'Industrie Canada applicables aux appareils radio exempts de licence.

L'exploitation est autorisée aux deux conditions suivantes:

- (1) l'appareil ne doit pas produire de brouillage, et
- (2) l'utilisateur de l'appareil doit accepter tout brouillage radioélectrique subi, même si le brouillage est susceptible d'en compromettre le fonctionnement.

12.联系我们

[ShenZhen ShengRun Technology Co.,Ltd.](http://www.tuner168.com)

地址:深圳市龙岗区宝龙街道宝荷路76号智慧家园1栋C座505
Address: Unit 505,Block C,First Building,Smart Park,No.76 Baohe Avenue,
Baolong Street, Longgang District, Shenzhen

全国业务直线: 400-8050-562

邮箱(E-mail): marketing@ttcble.com

电话(Telephone): 86-755-86233846

中文网址: www.tuner168.com

English Website: www.ttcble.com

电商平台(E-shop): <https://tuner168.1688.com/>

